

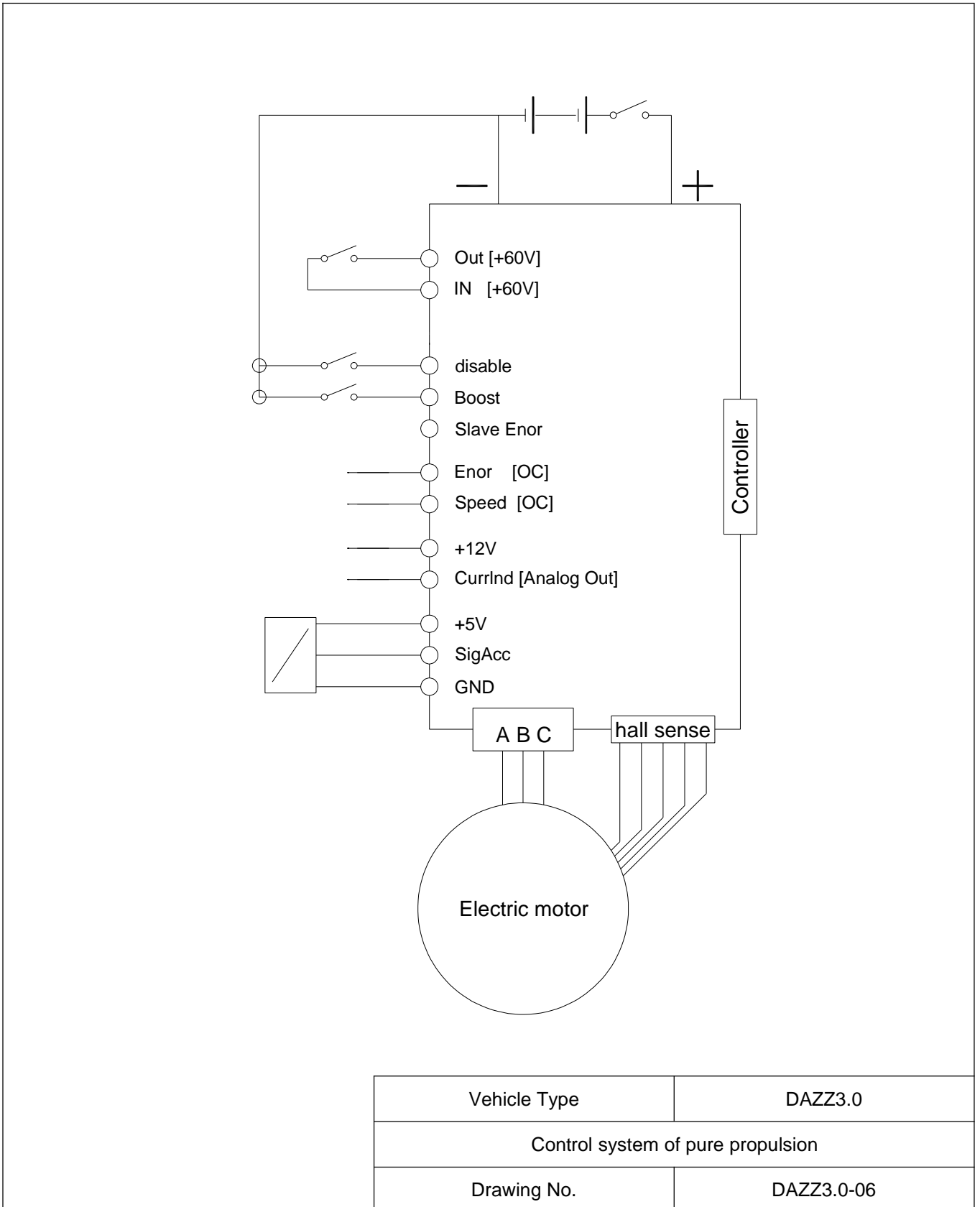

Elyx Smart Technology Holdings (Hongkong) Limited

Information document no.: 168/2013-DAZZ3.0-00

Application date: 30.12. 2019





Elyx Smart Technology Holdings (Hongkong) Limited

Information document no.: 168/2013-DAZZ3.0-00

Application date: 30.12. 2019

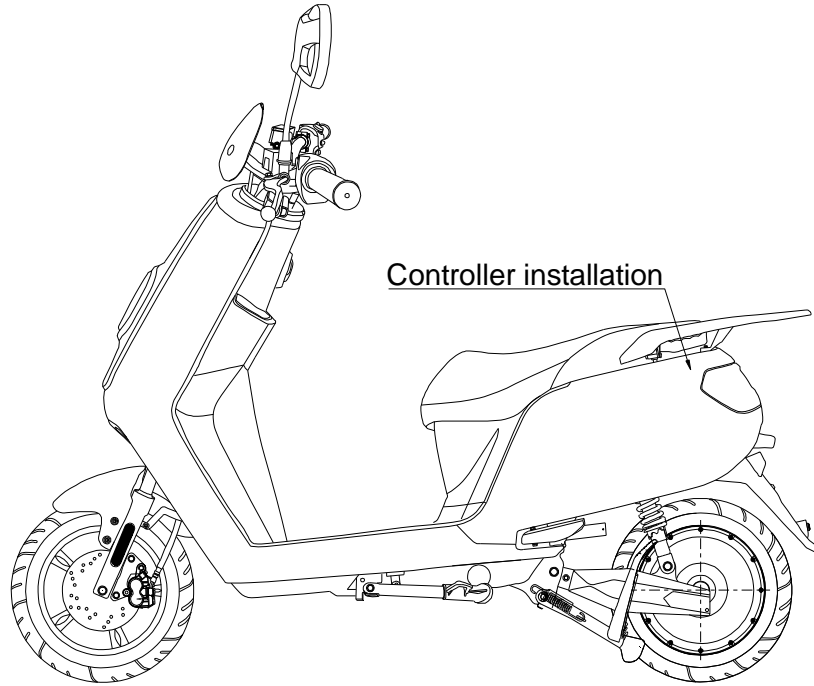

Detail:

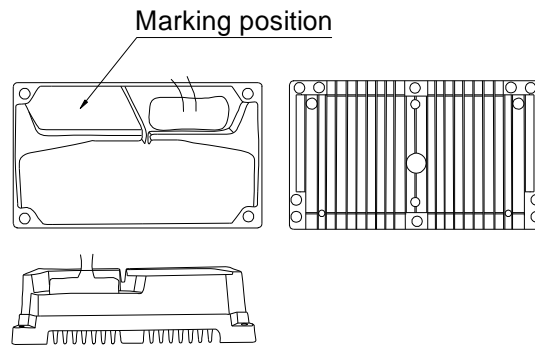

Manufacturer: Wuxi Lingbo Electronic Technology Co., Ltd.

Make: LINGBO

Type: LBMC060122HK2AU-23

Vehicle Type	DAZZ3.0
Installation of the controller	
Drawing No.	DAZZ3.0-09



Elyx Smart Technology Holdings (Hongkong) Limited

Information document no.: 168/2013-DAZZ3.0-00

Application date: 30.12. 2019

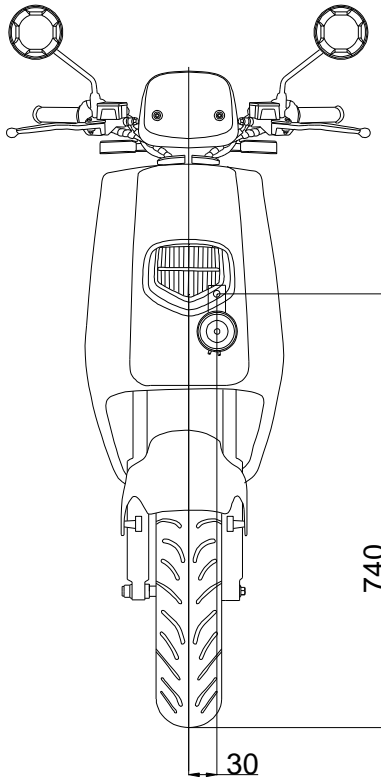

Detail:

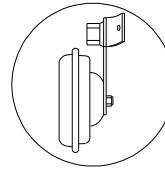

GB5787-86

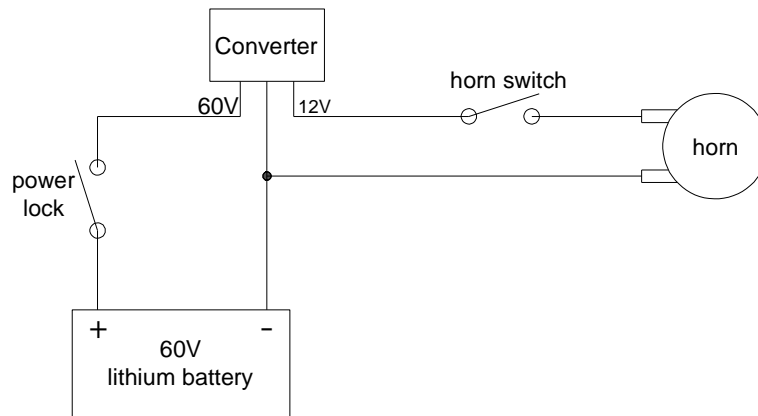
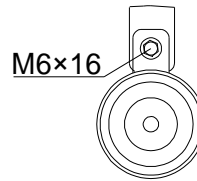

Make: LVEE
 Type: DL70-II
 Approval mark: II E32-000002

Vehicle Type	DAZZ3.0
Location of audible warning device	
Drawing No.	DAZZ3.0-12



Elyx Smart Technology Holdings (Hongkong) Limited

Information document no.: 168/2013-DAZZ3.0-00

Application date: 30.12. 2019

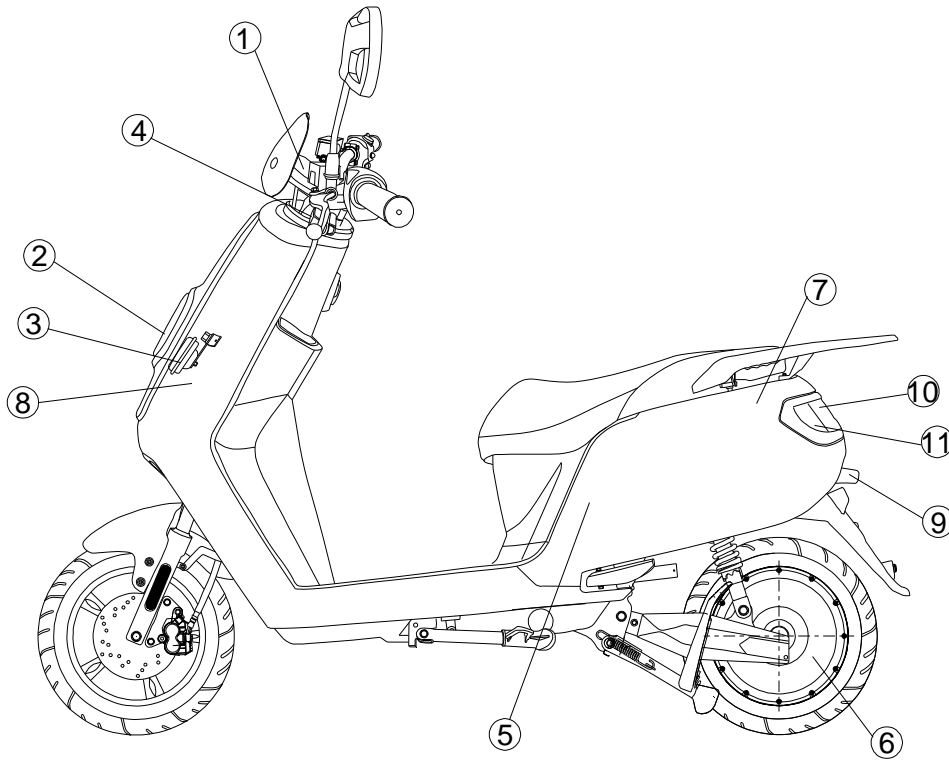

No.	Part Name	No.	Part Name
1	Speedometer	7	Controller
2	Head lamp passing beam	8	Converter
3	Horn	9	Rear registration plate lamp
4	Front direction indicator	10	Stop lamp/Rear position lamp
5	Battery	11	Rear direction indicator
6	Electric motor		

Vehicle Type	DAZZ3.0
Location of the power circuit components	
Drawing No.	DAZZ3.0-18



Elyx Smart Technology Holdings (Hongkong) Limited

Information document no.: 168/2013-DAZZ3.0-00

Application date: 30.12. 2019

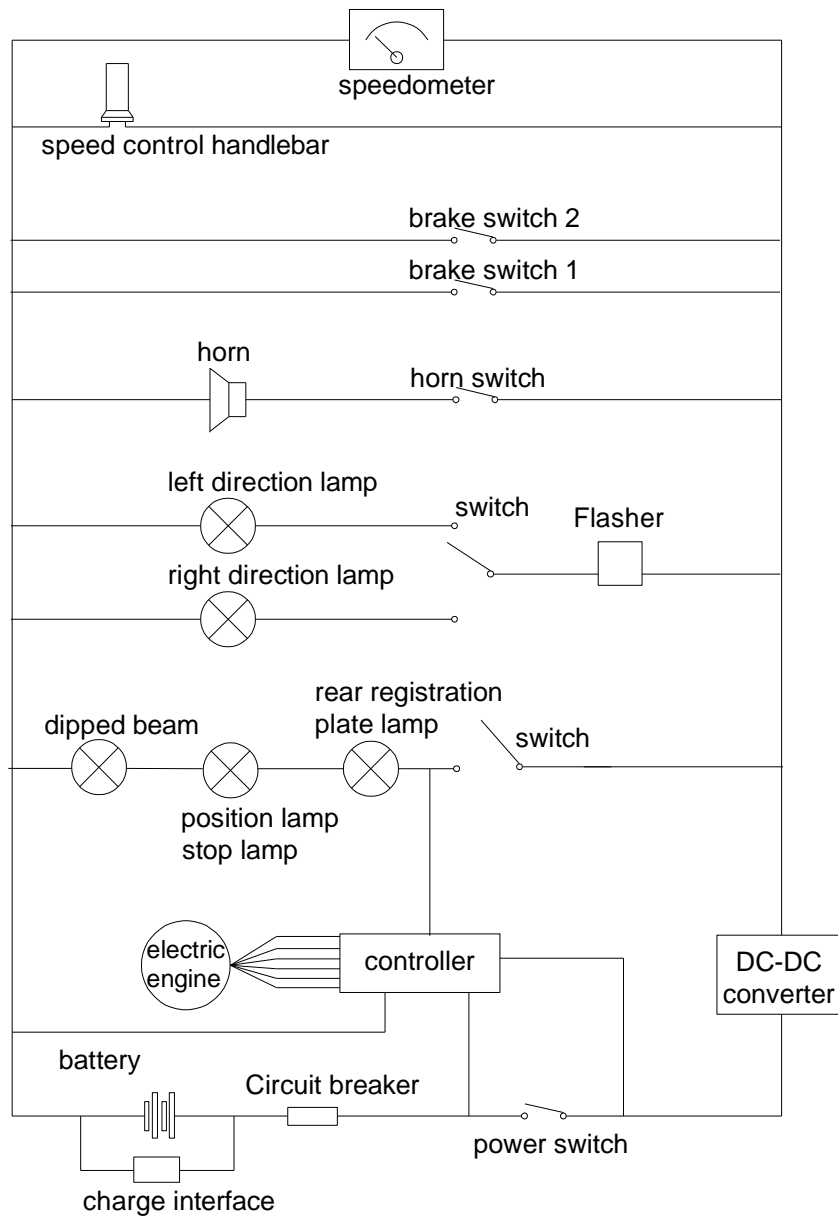

Vehicle Type	DAZZ3.0
Electric diagram	
Drawing No.	DAZZ3.0-20